

# PRODUCT SPECIFICATION



**PRODUCT TYPE: ACM-200**

**PRODUCT DESCRIPTION: MEMS CURRENT OUTPUT TYPE  
TRI-AXIS ACCELEROMETER**



## Contact Us

HANGZHOU MAIXINMINWEI TECHNOLOGY CORP., LTD

**Email:** [sales@memsmag.com](mailto:sales@memsmag.com)

**Whatsapp:** +8618151836753

**Tel/wechat:** +8618621961329

**Website:** [www.mxmwkj.com](http://www.mxmwkj.com)

## 1. Product characteristics

The ACM-200 tri-axis accelerometer is a widely used acceleration sensor series product produced by MXMW Hi-Tech Company with Swiss patented technology, which can be used in various fields such as vibration testing and impact testing. The product adopts output interface with 4~20mA and 0~20mA. Different address codes can be set, and multiple sensors can be connected in series for long-distance measurement and data analysis at multiple points. ACM-200 is a single crystal silicon capacitive sensor, consisting of a silicon chip that has undergone micro mechanical processing, a low-power ASIC for signal adjustment, a microprocessor for storing compensation values, and a temperature sensor.

The product has a small size, low power consumption, calibrated, fixed structure, and stable output. The new electronic configuration provides solid-state power for reset and comprehensive protection against overvoltage. The long-term stability and typical deviation of the proportional factor within the full range are less than 0.1%. This series of products has the characteristics of fixed structure, low power consumption, and excellent deviation stability, ensuring outstanding output reliability.

## 2. Product performance

- Tri-axis (X, Y, Z) optional
- Measuring range:  $\pm 1g/\pm 2g/\pm 4g/\pm 8g/\pm 16g/\pm 32g/\pm 40g$
- Voltage input: DC 9~36V
- Excellent deviation stability and vibration resistance
- Full range accuracy: 0.01g;
- High resolution: 0.001g
- Output mode: 4~20mA, 0~20mA optional
- Widely operating temperature: -55 ~ +100°C
- Size: (60\*59\*29mm) (can be customized)
- Protection level: IP67 (IP68 customized)

## 3. Product application

- Crash records, fatigue monitoring and prediction
- Ship navigation attitude measurement
- Roadbed analysis and high-speed railway fault detection
- Satellite solar antenna positioning
- Unmanned aerial vehicles
- Transportation system monitoring



#### 4. Product specification

Parameter	Conditions	ACM-200-2	ACM-200-8	ACM-200-40	Unit
Measuring range		±2	±8	±40	g
Bias calibration		<10	<50	<150	mg
Measuring axis	axis	X, Y, Z	X, Y, Z	X, Y, Z	
Zero bias stability (yearly)		1.5(<5)	7.5(<25)	22(<75)	mg
Resolution threshold	@Hz	<1	<5	<15	mg
Bias temperature coefficient	-55 ~ 100°	0.1	0.5	1.5	mg/°C
Bandwidth		0~≥400	0~≥400	0~≥400	Hz
Resonance frequency		1.6	6.7	6.7	KHz
Scale factor temperature coefficient		100	100	100	ppm/°C
		-50/250	-50/250	-50/250	max/min
Output signal	4~20mA, 0~20mA optional				
Reliability	MIL-HDBK-217, Level 2				
Impact resistance	20000g, 2ms, 1/2sine				
Anti-vibration	10grms、10 ~ 1000Hz				
Waterproof level	IP67				
Cable	Standard 1.5m length, wear-resistant, oil-proof, wide temperature, shielded cable 6*0.3mm <sup>2</sup>				
Weight	180g (excluding packaging box)				
Connector	6-pin aviation plug				
Capacitive loading	1000				

\* This performance parameter only lists ±2g, ±8g, ±40g series for reference, and for other measurement ranges, please refer to the nearest adjacent parameters

#### 5. Electrical indicators

Parameter	Condition	Minimum value	Typical value	Maximum value	Unit
Supply voltage		9	12	36	V
Working current			35		mA
Output load	resistive	0		500	kΩ
Operating temperature		-40		+85	°C
Storage temperature		-55		+100	°C

#### 6. Mechanical properties

<b>Connector</b>	Lead wire (1.5m) or waterproof aviation socket (customized)
<b>Protection level</b>	IP67
<b>Material</b>	Aluminum alloy frosted and oxidized
<b>Installation</b>	4 M4 screws

#### 7. Product dimension

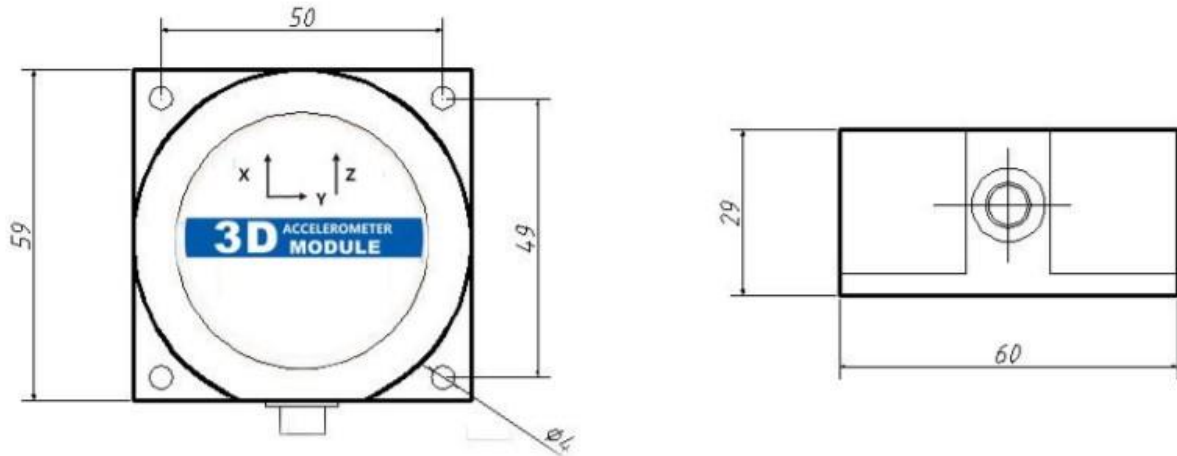

Product size: L60\*W59\*H29MM

### 8. Electrical connections

Thread Color Function	RED	BLACK	GREEN	YELLOW	WHITE	BROWN	BLUE
	1	2	3	4	5	6	7
	VCC Positive pole of power supply	GND Negative pole of power supply	RS232RXD	RS232TXD	Out X	Out Y	Out Z

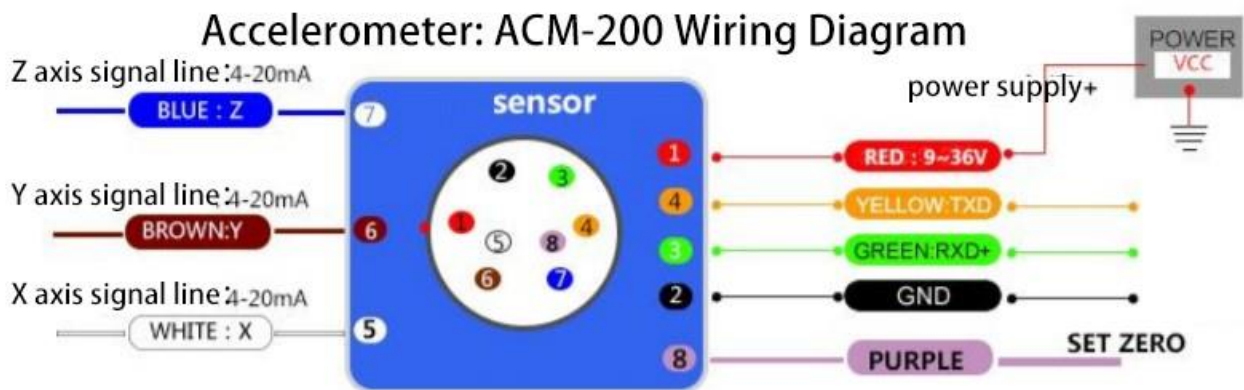

The output of ACM-200 is standard current 4~20mA, 0~20mA, corresponding to the minimum range and maximum range of acceleration measurement; when calculating the acceleration, just follow the ratio to get the corresponding acceleration value:

**For example:** ACM-200-2 (4~20mA): indicates  $\pm 2g$  measurement range, 4~20mA output current

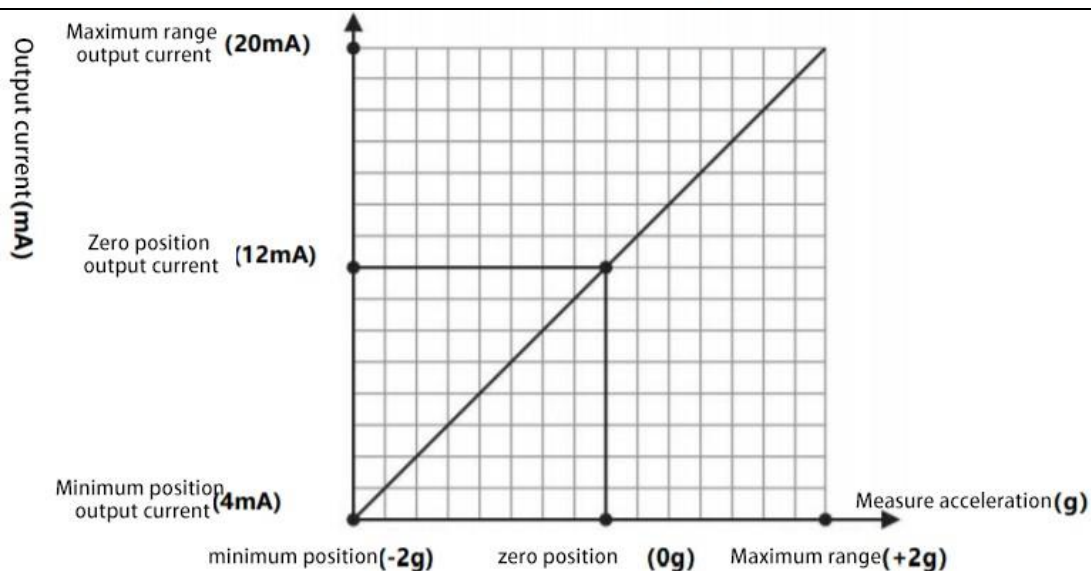

### 9. Product measurement direction

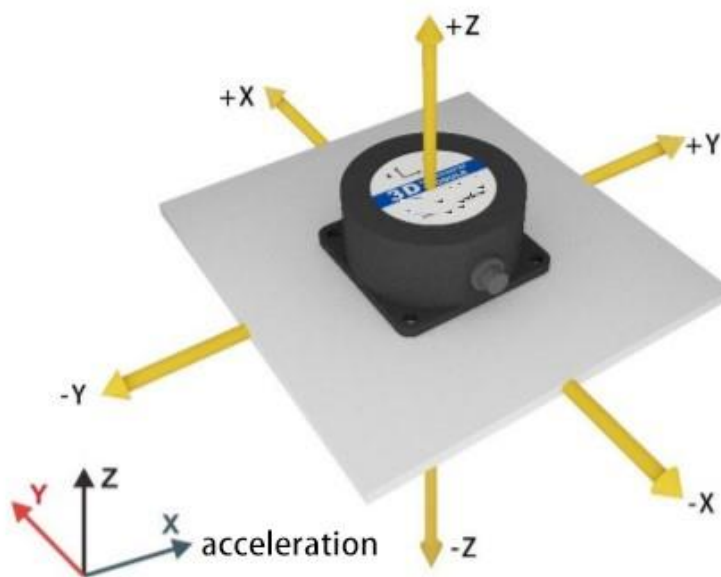

### 10. Debugging software

You can download the accelerometer debugging assistant on the official website of MXMW Company ([www.mxmwkj.com](http://www.mxmwkj.com)) to set the analog range. If you want to directly access the accelerometer, you can access it through the communication protocol of the accelerometer and the Volkswagen version of the serial port debugging assistant, so that the sensor can be easily integrated into your system



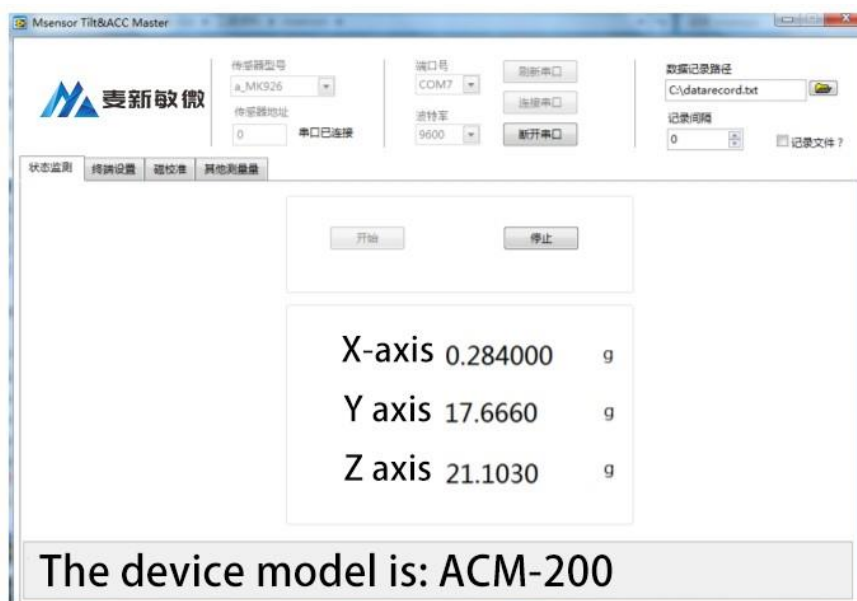

### Accelerometer Debugging Assistant

- Device model:** Select the corresponding product model
- Serial port:** Select the COM port corresponding to the device;
- Device address:** fill in the current address code of the sensor, the factory default is 00
- Baud rate:** Select the current baud rate of the sensor, the factory default is 9600
- Status monitoring:** Connect to the serial port and click Start to collect data.
- Status setting:** Set the sensor function parameters

## 11. Communication protocol

1) **Data frame format:** (8 data bits, 1 stop bit, no parity, default rate 9600)

Identifier	Data length	Address code	Command word	Data field	Checksum
(1byte)	(1byte)	(1byte)	(1byte)		(1byte)
0x68					

**Data format:** hexadecimal

**Identifier:** fixed to 0x68

**Data length:** length from data length to checksum (including checksum)

**Address code:** the address of the collection module, the default is 0x00

**Data field:** The content and length of the command word vary accordingly.

**Checksum:** the sum of data length, address code, command word and data field, regardless of carry  
(Note: when the command word or data field changes, the checksum will change. When you change the data field, please change the checksum accordingly.)

**Unit:** g

## 2) Command format

### 2.1 Read X-axis (acceleration)

**Send command:** 68 04 00 01 05

Identifier	Data length	Address code	Command word	Data field	Checksum
(1byte)	(1byte)	(1byte)	(1byte)	(0byte)	(1byte)
0x68			0x01		

**Answer command:**

Identifier	Data length	Address code	Command word	Data field	Checksum
(1byte)	(1byte)	(1byte)	(1byte)	(3byte)	(1byte)
0x68			0x81	SXX.YYY	

**Note:** The data field is 3 bytes to return the acceleration value, which is a compressed BCD code. S is the sign bit (0 positive, 1 negative), XX is a two-digit integer value, and YYY is a decimal value. The other axis data are the same. For example, 10 26 87 means -2.687g.

## 2.2 Read Y-axis (acceleration)

**Send command:** 68 04 00 02 06

Identifier	Data length	Address code	Command word	Data field	Checksum
(1byte)	(1byte)	(1byte)	(1byte)	(0byte)	(1byte)
0x68			0x02		

**Answer command:**

Identifier	Data length	Address code	Command word	Data field	Checksum
(1byte)	(1byte)	(1byte)	(1byte)	(3byte)	(1byte)
0x68			0x82	SXX.YYY	

## 2.3 Read Z-axis (acceleration)

**Send command:** 68 04 00 03 07

Identifier	Data length	Address code	Command word	Data field	Checksum
(1byte)	(1byte)	(1byte)	(1byte)	(0byte)	(1byte)
0x68			0x03		

**Answer command:**

Identifier	Data length	Address code	Command word	Data field	Checksum
(1byte)	(1byte)	(1byte)	(1byte)	(3byte)	(1byte)
0x68			0x83	SXX.YYY	

## 2.4 Read X, Y, Z axis acceleration

**Send command:** 68 04 00 04 08

Identifier	Data length	Address code	Command word	Data field	Checksum
(1byte)	(1byte)	(1byte)	(1byte)	(0byte)	(1byte)
0x68			0x04		

Answer command:

Identifier	Data length	Address code	Command word	Data field	Checksum
(1byte)	(1byte)	(1byte)	(1byte)	(9byte)	(1byte)
0x68			0x84	SXX.YYY	

**Note:** The data field contains 9 bytes for the X-axis, Y-axis, and Z-axis values, which are compressed BCD codes. Every three bytes form a group. For example, returning a command: 68 0D 00 84 00 02 01 10 00 58 04 05 00 32, where the X-axis is 00 02 10, the Y-axis is 10 00 58, and the Z-axis is 04 05 00. For each axis, return three bytes of the value in SXX format YYY, S represents the sign digit, XX represents the two digit integer value, and YYY represents the three decimal places value. The readings for the three corresponding axes in this example are 2.01g, -0.058g, and 40.500g, respectively.

**Note:** The returned 9bytes are divided into 3 groups, namely the X-axis, Y-axis, and Z-axis; Please refer to instruction 2.1 for parsing format

**X-axis: +00.201g, Y-axis: -00.058g, Z-axis: 40.500g**

**68 0D 00 84 00 02 01 10 00 58 04 05 00 32**

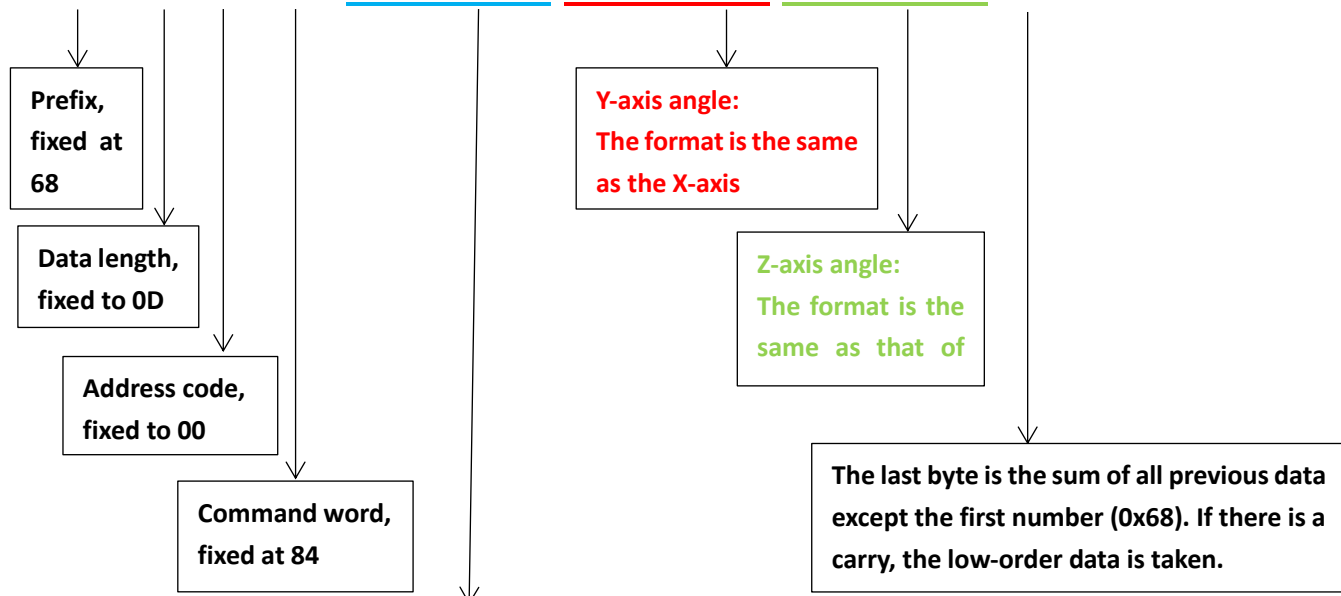

**X-axis angle:**  
 The first bit of the first byte is the sign bit, 0 represents a positive angle, and 1 represents a negative angle.  
 The second digit of the first byte and the second byte are the integer bits of the angle, which are compressed BCD codes.  
 The second digit of the first byte and the third byte are decimal places and are compressed BCD codes.



## 2.5 Accelerometer calibration

Send command: 68 04 00 3D 41

Identifier	Data length	Address code	Command word	Data field	Checksum
(1byte)	(1byte)	(1byte)	(1byte)	(0byte)	(1byte)
0x68			0x3D		

Answer command:

Identifier	Data length	Address code	Command word	Data field	Checksum
(1byte)	(1byte)	(1byte)	(1byte)	(1byte)	(1byte)
0x68	05		0x6D	0x00: Setting successful 0xFF: Setting failed	

**Note:** Accelerometer calibration is used to remove the zero bias of accelerometers X, Y, and Z. The calibration method for accelerometer is as follows: keep the accelerometer module horizontally stationary and perform calibration.

## 2.6 Set communication rate

Send command: 68 05 00 0B 03 13

Identifier	Data length	Address code	Command word	Data field	Checksum
(1byte)	(1byte)	(1byte)	(1byte)	(1byte)	(1byte)
0x68			0x0B		

Answer command:

Identifier	Data length	Address code	Command word	Data field	Checksum
(1byte)	(1byte)	(1byte)	(1byte)	(1byte)	(1byte)
0x68			0x8B	0x00: Setting successful 0xFF: Setting failed	

**Notes:** 0x00 represents 2400, 0x01 represents 4800, 0x02 represents 9600, 0x03 represents 19200, 0x04 represents 115200, 0x05 represents 14400, 0x06 represents 38400, 0x07 represents 57600, and the default value is 0X02:9600. If the baud rate is set to 19200, the command is 68 05 00 0B 03 13, where 13 = 05+ 00+ 0B+ 03, and so on when setting other baud rates.

**More Notes:** After setting the baud rate, the device will return a response command at the original baud rate. Afterwards, the baud rate setting will take effect, and the upper computer needs to make corresponding baud rate changes in order to communicate with the device again.

## 2.7 Set output model

Send command: 68 05 00 0C 00 11

Identifier	Data length	Address code	Command word	Data field	Checksum
(1byte)	(1byte)	(1byte)	(1byte)	(1byte)	(1byte)
0x68			0x0C	0x00: Q&A 0x01: 5Hz auto-output mode 0x02: 15Hz auto-output mode 0x03: 25Hz auto-output mode 0x04: 35Hz auto-output mode 0x05: 50Hz auto-output mode 0x06:100Hz auto-output mode 0x07:200Hz auto-output mode 0x08:300Hz auto-output mode	

\*The default output mode is 00; if the device is in non-response mode, there will be an idle time of 10s without sending data after each power-on and restart, and the continuous data output mode will start after 10s.

Answer command:

Identifier	Data length	Address code	Command word	Data field	Checksum
(1byte)	(1byte)	(1byte)	(1byte)	(1byte)	(1byte)
0x68			0x8C	0x00: Setting successful 0xFF: Setting failed	

**Note:** When using the RS485 interface, as the RS485 interface operates in half duplex mode, it may not be able to effectively receive input commands when the product automatically outputs data outward. At this point, you may need to repeatedly send commands to the product in order to receive them. Therefore, if you need to send commands to interact with the RS485 interface product during use, it is recommended to set the product to work in Question and Answer mode. In addition, when the product is set to automatic output mode, there will be no output within 10 seconds after the product is powered on, and the product can effectively receive external setting commands.

## 2.8 Set module address

Send command: 68 05 00 0F 01 15

Identifier	Data length	Address code	Command word	Data field	Checksum
(1byte)	(1byte)	(1byte)	(1byte)	(1byte)	(1byte)
0x68			0x0F	XX module address	

**Note:** The default address of the sensor is 00.

**Answer command:**

Identifier	Data length	Address code	Command word	Data field	Checksum
(1byte)	(1byte)	(1byte)	(1byte)	(1byte)	(1byte)
0x68			0x8F	0x00: Setting successful 0xFF: Setting failed	

- 1) If multiple sensors are connected to a group of buses at the same time, such as RS485, each sensor needs to be set to a different address to achieve separate control and response speed.
- 2) If the new address is successfully changed, the address codes in all subsequent command and response packets must be replaced by the changed new address code to take effect, otherwise the sensor will not respond to the command.
- 3) XX module address ranges from 00 to EF.

## 2.9 Query module address

**Send command:** 68 04 00 1F

Identifier	Data length	Address code	Command word	Data field	Checksum
(1byte)	(1byte)	(1byte)	(1byte)	(0byte)	(0byte)
0x68	04	00	1F		

**Note:** Checking the module address does not consider the check digit.

**Answer command:**

Identifier	Data length	Address code	Command word	Data field	Checksum
(1byte)	(1byte)	(1byte)	(1byte)	(1byte)	(1byte)
0x68			0x1F		

## 2.10 update flash (Save settings)

**Send command:** 68 04 00 0A 0E

Identifier	Data length	Address code	Command word	Data field	Checksum
(1byte)	(1byte)	(1byte)	(1byte)	(0byte)	(1byte)
0x68			0x0A		

**Answer command:**

Identifier	Data length	Address code	Command word	Data field	Checksum
(1byte)	(1byte)	(1byte)	(1byte)	(1byte)	(1byte)

0x68			0x8A	0x00: Setting successful 0xFF: Setting failed	
------	--	--	------	--	--

\*For various parameter settings, if the save **setting command** is not sent after the settings are completed, these settings will disappear after power failure.

### 2.11 Factory default

**Send command:** 68 04 00 0E 12

Identifier	Data length	Address code	Command word	Data field	Checksum
(1byte)	(1byte)	(1byte)	(1byte)	(0byte)	(1byte)
0x68			0x0E		

**Answer command:**

Identifier	Data length	Address code	Command word	Data field	Checksum
(1byte)	(1byte)	(1byte)	(1byte)	(1byte)	(1byte)
0x68			0x8E	0x00: Setting successful 0xFF: Setting failed	