

# PRODUCT SPECIFICATION



**PRODUCT TYPE: AC-2**

**PRODUCT DESCRIPTION: QUARTZ ACCELEROMETER**



## CONTACT US

HANGZHOU MAIXINMINWEI TECHNOLOGY CORP., LTD

EMAIL: [sales@memsmag.com](mailto:sales@memsmag.com)

WHATSAPP: +8618151836753

TEL/WECHAT: +8618621961329

WEBSITE: [www.mxmwkj.com](http://www.mxmwkj.com)

## 1. Introduction

AC-2 quartz flexible accelerometer series is a high-precision inertial navigation level accelerometer for a large number of military applications (up to 100g). The product has excellent long-term stability, repeatability, start-up performance, environmental adaptability and high reliability, which can be used for static test or dynamic test. It is also a standard vibration sensor and inclination sensor.

The output current of the product has a linear relationship with the force or acceleration received. Users can select the appropriate sampling resistance through calculation to achieve high precision output. And according to user needs built-in temperature sensor, used to offset value and scale factor compensation, reduce the impact of environmental temperature.

**Applications:** inertial measurement of military high-precision inertial navigation system in aerospace, aviation, ships, weapons and other fields and precision instrument equipment vibration isolation test and inclination test.

## 2. Main parameter

Parameters	AC-2A	AC-2B	AC-2C	Unit
Range (40ohms)	±70			g
Threshold /Resolution	2	3	4	μg
Bias k0/k1	≤±3	≤±3	≤±5	mg
Scale factor k1	0.8 ~ 1.20			mA/g
Class II nonlinearity coefficient k2/k1	≤±10	≤±15	≤±20	μg /g <sup>2</sup>
0g 4 hours short time stability	≤10	≤15	≤20	μg
1g 4 hours short time stability	≤10	≤15	≤20	ppm
Bias drift Sigma k0( 1σ, one month)	≤10	≤20	≤30	μg
Repeatability of scale factor Sigma k1/k1 (1σ, one month)	≤15	≤30	≤50	ppm
Class II nonlinearity Coefficient repeatability k2/k1 (1σ, one month)	≤±10	≤±20	≤±30	μg /g <sup>2</sup>
Bias thermal coefficient	≤±10	≤±30	≤±50	μg /°C
Scale factor thermal coefficient	≤±20	≤±30	≤±50	ppm /°C
Noise (sample resistance 840Ω)	≤5			mv
Natural Frequency	400~800			Hz
Bandwidth	800~2500			Hz
Vibration	6g			20~2000Hz
Shock	100g			8ms, 1/2s in
Temperature range (Operating)	-55~+85			°C
Temperature range (saved)	-60~+120			°C
Power	±12~±15			V
Consume current	≤±20			mA
Temp. sensor	Optional			
Size	Φ25.4X30			mm
Weight	≤80			g

DISCLAIMER: Specifications are subject to change without notice. MXMW Company reserves the right to make changes to any product or technology herein to improve reliability, function or design.

### 3. Configuration drawing and interface

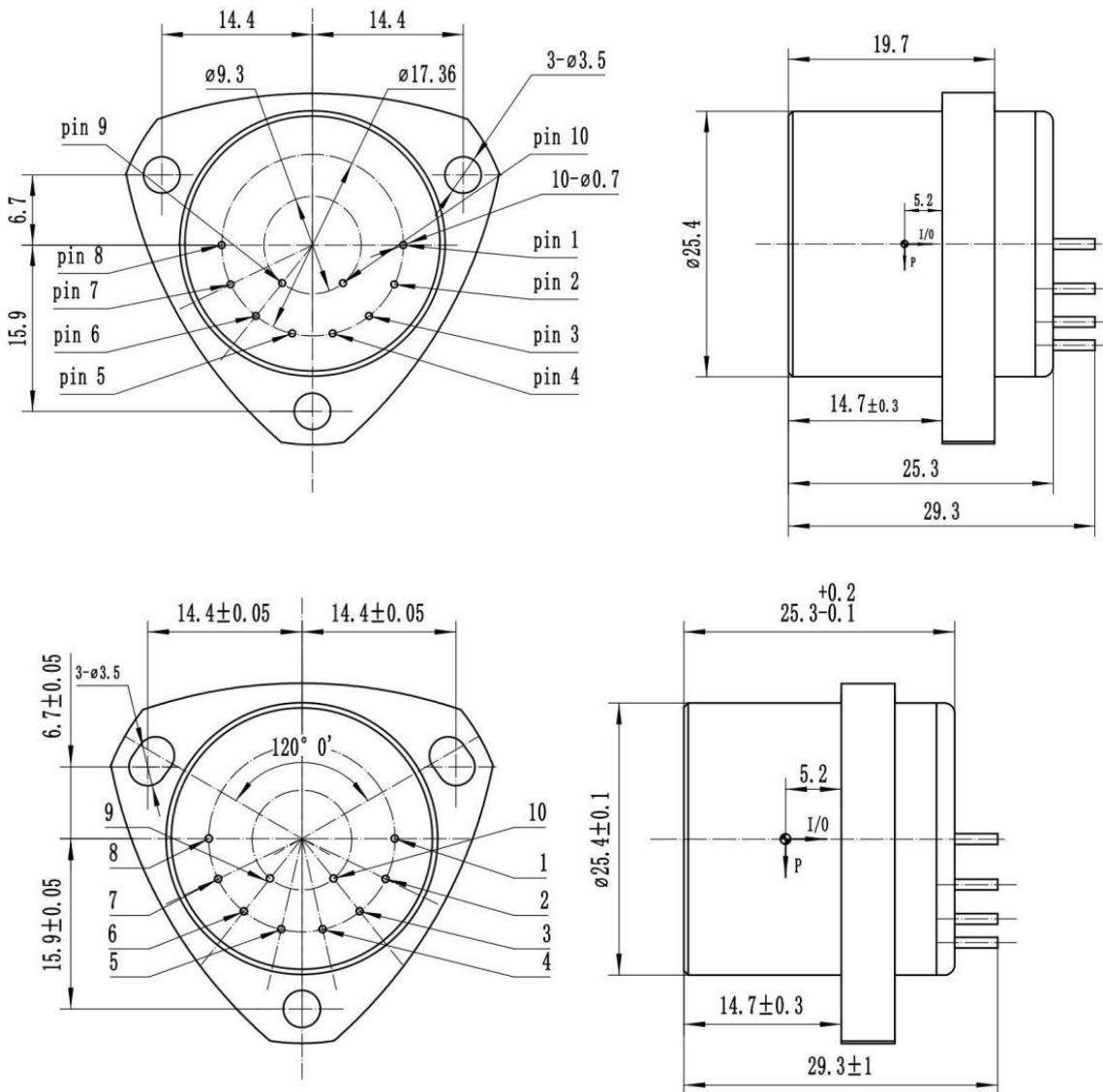

Mark: The temperature sensor AD590 / PT1000 optional; Point 10 is the high power. The point 9 is the low power. The point 9 and power ground use one platinum resistance; the value is 1K, the thermal coefficient is less than 5ppm.

## 4. Methodology

### 4.1 Scope

The technical requirements for Accelerometer are defined in Section 3.

### 4.2 Applicable documents

- IEEE 1293-1998: IEEE Standard Specification Format Guide and Test Procedure for Linear, Single-Axis, Nongyroscopic Accelerometers
- IEEE 337-1972: IEEE Standard Specification Format Guide and Test Procedure for Linear, Single-Axis, Pendulous, Analog, Torque Balance Accelerometers
- IEEE 530-1978: IEEE Standard Specification Format Guide and Test Procedure for Linear, Single-Axis, Digital, Torque Balance Accelerometers
- IEEE 836-2001: IEEE Recommended Practice for Precision Centrifuge Testing of Linear Accelerometers
- IEEE 836-2001: IEEE Recommended Practice for Inertial Sensor Test Equipment, Instrumentation, Data Acquisition and Analysis
- IEEE 528-2001: IEEE Standard Inertial Sensor Terminology

### 4.3 Requirements

The Accelerometer requirements not specified in this document shall conform to the documents mentioned in 2.

### 4.3.1 Type

The Accelerometer shall be linear, single-axis, torque-balance and non-gyroscopic.

### 4.3.2 Application

The Accelerometer shall be used in inertial navigation and control systems of aerospace vehicles.

### 4.3.3 Scale factor parameters

The required instrumentation for bias /scale factor/ second order nonlinearity repeatability measurements is given below:

- Mult-tooth index head for rotating the Accelerometer
- Rotating fixture for fixing the Accelerometer
- Environmental test cabin for changing the measurement temperature
- Electronics for reading and storing the Accelerometer measurements

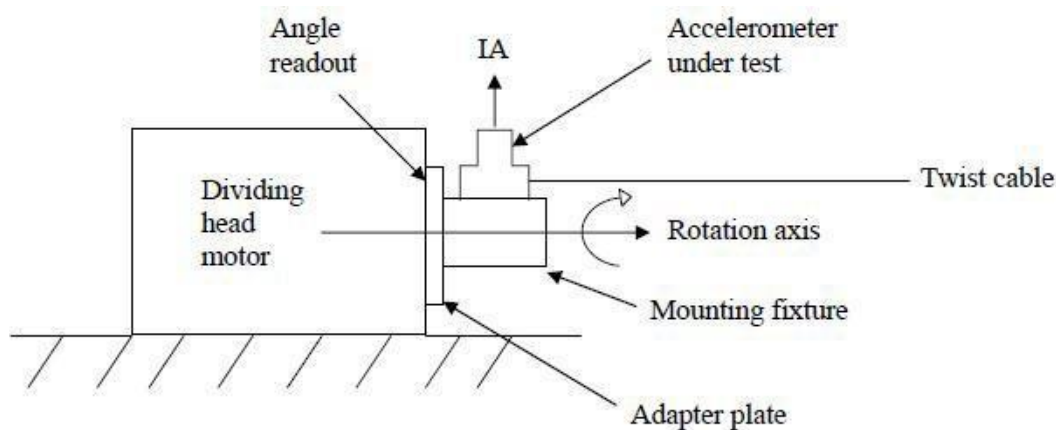



Repeatability test equipment

Figure 1: The Layout of Accelerometer Rotation Test Setup

#### 4.3.4 Scale factor

The scale factor of the Accelerometer shall be  $1\pm 0.15$  or  $0.8\pm 0.2\text{mA/g}$ . The calculation of the scale factor shall be as follows:

$$K_1 = \frac{I_0 + I_{180}}{2} \quad (1)$$

$K_1 = \text{Scale factor}$

$I_0 = \text{The output of the Accelerometer at } 0^\circ \vec{IA} \text{ antiparallel to } \vec{g}$

$I_{180} = \text{The output of the Accelerometer at } 180^\circ \vec{IA} \text{ parallel to } \vec{g}$



### 4.3.5 Scale factor temperature coefficient



Temperature coefficient value test equipment

The scale factor temperature coefficient of the Accelerometer shall be smaller than 50ppm/°C. The calculation of the scale factor temperature coefficient shall be as follows:

$$\zeta_{K_1}(T_1 \dots T_2) = \frac{K_1(T_2) - K_1(T_1)}{T_2 - T_1} \quad (2)$$

$\zeta_{K_1}(T_1 \dots T_2)$ : Scale factor temperature coefficient between  $T_1$  and  $T_2$

$T_1$ : Initial temperature

$T_2$ : Final Temperature

$K_1(T_1)$ : Scale factor at  $T_1$

$K_1(T_2)$ : Scale factor at  $T_2$

We will test it from -55°C~+85°C, the temperature point from -55°C, -35°C, -15°C, 5°C, 25°C, 45°C, 65°C, 85°C

Temperature coefficient  $\delta k_1(-55 \sim +85^\circ\text{C}) = \delta(-55 \sim -35^\circ\text{C}) + \delta(-35 \sim -15^\circ\text{C}) +$



$$\frac{\delta(-15 \sim +5^{\circ}\text{C}) + \delta(+5 \sim +25^{\circ}\text{C}) + \delta(+25 \sim +45^{\circ}\text{C}) + \delta(+45 \sim +65^{\circ}\text{C}) + \delta(+65 \sim +85^{\circ}\text{C})}{7}$$

#### 4.3.6 Scale factor repeatability (1/3months)

The scale factor repeatability (1/3months) of the Accelerometer shall be 30ppm or 50ppm. The calculation of the scale factor repeatability (1/3months) shall be as follows (the Accelerometer shall be turned off after the initial measurement):

The scale factor repeatability (1/3months) of the Accelerometer shall be smaller than 50ppm. The calculation of the scale factor repeatability (1/3months) shall be as follows (the Accelerometer shall be turned off after the initial measurement): we will test it 10 times (10 days one time), we will get 10 data K1(0), K1(1), K1(2), K1(3), K1(4), K1(5), K1(6), K1(7), K1(8), K1(9)

$$\bar{k}_1 = \frac{\sum_{i=0}^9 k_1(i)}{10}$$

$$\sigma_{k_1/k_1} = \sqrt{\frac{\sum_{i=0}^9 (k_1(i) - \bar{k}_1)^2}{10-1}} / \bar{k}_1$$

#### 4.4 Bias parameters

The required instrumentation for bias measurements is the same as scale factor measurements.

##### 4.4.1 Bias

The bias of the Accelerometer shall be smaller than 4 mg. The calculation of the bias shall be as follows:

$$K_0 = \frac{I_{270} - I_{90}}{2 \times K_1} \quad (4)$$

$$K_0 = \text{Bias}$$

$$I_{270} = \text{The output of the Accelerometer at } 270^{\circ}$$

$I_{90} = \text{The output of the Accelerometer at } 90^\circ$

#### 4.4.2 Bias temperature coefficient

The test equipment is same as scale factor

The bias temperature coefficient of the Accelerometer shall be  $50\mu\text{g}/^\circ\text{C}$ . The calculation of the bias temperature coefficient shall be as follows:

$$\zeta_{K_0}(T_1 \dots T_2) = \frac{K_0(T_2) - K_0(T_1)}{T_2 - T_1} \quad (5)$$

$\zeta_{K_0}(T_1 \dots T_2)$ : Bias temperature coefficient between  $T_1$  and  $T_2$

$T_1$ : Initial temperature

$T_2$ : Final Temperature

$K_0(T_1)$ : Bias at  $T_1$

$K_0(T_2)$ : Bias at  $T_2$

We will test it from  $-55^\circ\text{C} \sim +85^\circ\text{C}$ , the temperature point from  $-55^\circ\text{C}$ ,  $-35^\circ\text{C}$ ,  $-15^\circ\text{C}$ ,  $5^\circ\text{C}$ ,  $25^\circ\text{C}$ ,  $45^\circ\text{C}$ ,  $65^\circ\text{C}$ ,  $85^\circ\text{C}$

Temperature coefficient  $\delta k_0(-55 \sim +85^\circ\text{C}) = \delta(-55 \sim -35^\circ\text{C}) + \delta(-35 \sim -15^\circ\text{C}) + \delta(-15 \sim +5^\circ\text{C}) + \delta(+5 \sim +25^\circ\text{C}) + \delta(+25 \sim +45^\circ\text{C}) + \delta(+45 \sim +65^\circ\text{C}) + \delta(+65 \sim +85^\circ\text{C})$

#### 4.4.3 Bias repeatability (1/3months)

Bias repeatability (1 months) of the Accelerometer shall be smaller than  $20\mu\text{g}$  or  $40\mu\text{g}$ .

The calculation of the bias repeatability (1 months) shall be as follows (the Accelerometer shall be turned off after the initial measurement):

**(According to the requirements of technical indicators to decide whether to use 1 month or 3 months standard)**

$$\Delta_{K_b}(0 \dots 3M) = \frac{K_0(3M) - K_0(0)}{2} \quad (6)$$

$\Delta K_0(0 \dots 3M)$ : Bias repeatability for 3 months

$K_0(3M)$ : Bias measurement after 3 months

$K_0(0)$ : Initial bias measurement

Bias repeatability (1/3months) of the Accelerometer shall be smaller than 20 $\mu$ g or 40 $\mu$ g. The calculation of the bias repeatability (1/3months) shall be as follows (the Accelerometer shall be turned off after the initial measurement): we will test it 10 times (10 days one time) ,we will get 10 data  $K_0(0)$ ,  $K_0(1)$ ,  $K_0(2)$ ,  $K_0(3)$ ,  $K_0(4)$ ,  $K_0(5)$ ,  $K_0(6)$ ,  $K_0(7)$ ,  $K_0(8)$ ,  $K_0(9)$

$$\bar{k}_0 = \frac{\sum_{i=0}^9 k_0(i)}{10}$$
$$\sigma_{k_0} = \sqrt{\frac{\sum_{i=0}^9 (k_0(i) - \bar{k}_0)^2}{10 - 1}}$$

#### 4.4.4 Bias drift

Bias drift of the Accelerometer shall be smaller than 100µg. The calculation of the bias drift shall be as follows:

Take and record 30 Accelerometer measurements, each averaged over 30 seconds. The bias drift is the standard deviation of those 30 measurements.

#### BIAS DRIFT VARIATION UNDER RANDOM VIBRATION

Bias drift variations of the Accelerometer before, during and after the random vibration shall be 50µg. The calculation of the bias drift variation shall be as follows:

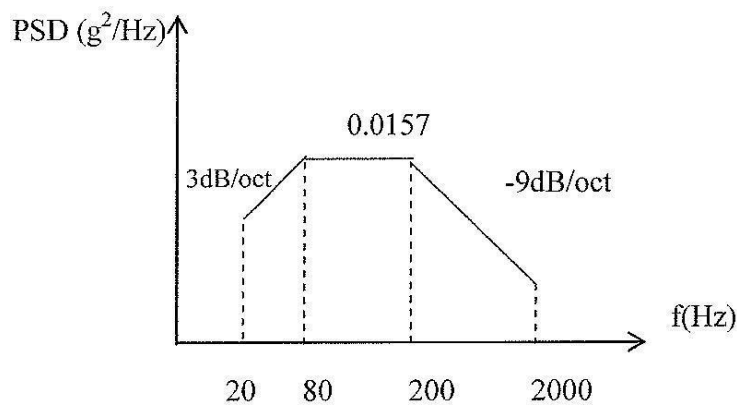

Figure 1: Random Vibration Profile

$$\Delta K_0(l \rightarrow v) = K_0(v) - K_0(l) \quad (7)$$

$$\Delta K_0(v \rightarrow f) = K_0(f) - K_0(v) \quad (8)$$

$\Delta K_0(l \rightarrow v)$ : The variation between the averages of bias drift during and before the random vibration, respectively

$K_0(v)$ : The average of the bias drift during the random vibration

$K_0(l)$ : The average of the bias drift before the random vibration

$\Delta K_0(v \rightarrow f)$ : The variation between the averages of bias drift after and during the random vibration, respectively

$K_0(f)$ : The average of the bias drift after the random vibration

#### 4.4.4 Bias instability

Bias instability of the Accelerometer shall be smaller than  $10\mu\text{g}$ . Bias instability shall be determined from the value of Allan Variance curve where the slope is 0.

### 4.5 Axis misalignment parameters

The required instrumentation for axis misalignment measurements is the same as scale factor measurements.

#### 4.5.1 Axis misalignment

Axis misalignment of the Accelerometer shall be smaller than  $2000 \mu \text{ rad}$ . The calculation of axis misalignment shall be as follows:

$$\Omega \uparrow = \frac{(I_{270 \uparrow}) - (I_{90 \uparrow})}{2 + K_1} \quad (9)$$

$$\Omega \rightarrow = \frac{(I_{270 \rightarrow}) - (I_{90 \rightarrow})}{2 + K_1} \quad (10)$$

$\Omega \uparrow$  = Axis misalignment corresponding to original measurement position

$I_{270 \uparrow}$  : The output of the Accelerometer at  $270^\circ$  for original measurement position

$I_{90 \uparrow}$  : The output of the Accelerometer at  $90^\circ$  for original measurement position

$\Omega \rightarrow$  : Axis misalignment corresponding to the measurement

position, where the Accelerometer is rotated 90° clockwise

$I_{270}$  → : The output of the Accelerometer at 270° for the measurement

position, where the Accelerometer is rotated 90° clockwise

$I_{90}$  → : The output of the Accelerometer at 90° for the measurement

position, where the Accelerometer is rotated 90° clockwise

#### 4.5.2 Axis misalignment repeatability

Axis misalignment repeatability of the Accelerometer shall be smaller than 500μrad. The calculation of axis misalignment repeatability shall be as follows (the Accelerometer shall be turned off after the initial measurement):

$$\Delta\Omega \uparrow = \frac{(\Omega \uparrow_f) - (\Omega \uparrow_i)}{2} \quad (11)$$

$$\Delta\Omega \rightarrow = \frac{(\Omega \rightarrow_f) - (\Omega \rightarrow_i)}{2} \quad (12)$$

$\Delta\Omega \uparrow$  : Axis misalignment repeatability for original measurement

position

$\Omega \uparrow_f$ : Final axis misalignment for original measurement position

$\Omega \uparrow_i$ : Initial axis misalignment for original measurement position

$\Delta\Omega \rightarrow$  : Axis misalignment repeatability for rotated measurement

position

$\Omega \rightarrow_f$ : Final axis misalignment for rotated measurement position

**$\Omega \rightarrow z$ : Initial axis misalignment for rotated measurement position****4.6 Nonlinearity parameters**

The required instrumentation for nonlinearity parameters is the same as scale factor measurements.

**4.6.1 Second order nonlinearity**

The second order nonlinearity of the Accelerometer shall be smaller than  $20\mu\text{g}/\text{g}^2$ . The measurement and calculation of second order nonlinearity of the Accelerometer shall be as follows:

At each dividing head angle  $\theta = 0^\circ, \theta_n, 2\theta_n, \dots, k\theta_n \dots, (n-1)\theta_n$  take and record  $m$  Accelerometer measurements ( $E_0$ ) for each individual position averaged over a time  $t$ , where  $\theta_n = 360/n$ ,  $n, m$  and  $k$  are integers, and  $0 \leq k \leq n-1$ .

1. Take average of  $m$  measurements for each individual position.
2. Calculate the component of gravitational acceleration parallel to the measurement axis of the Accelerometer for each position

$$\alpha = -\frac{\cos(k + \theta_n) \times \pi}{180} \quad (13)$$

3. Make a second order equation fit of the values between Accelerometer measurements calculated in 2 and gravitational acceleration components calculated in 3:

$$E_0 = K_0 + K_1 \times \alpha + K_2 \times \alpha^2 \quad (14)$$

**$K_2$ : Second order nonlinearity**



### 4.6.2 Second order nonlinearity repeatability (1/3months)

The second order nonlinearity repeatability (1/3months) of the Accelerometer shall be smaller than  $20\mu\text{g}/\text{g}^2$ . The calculation of the second order nonlinearity repeatability (1/3months) shall be as follows (the Accelerometer shall be turned off after the initial measurement):

The second order nonlinearity repeatability (1/3months) of the Accelerometer shall be smaller than  $20\mu\text{g}/\text{g}^2$ . The calculation of the bias repeatability (1/3months) shall be as follows (the Accelerometer shall be turned off after the initial measurement): we will test it 10 times (10 days one time), we will get 10 data  $K_2(0)$ ,  $K_2(1)$ ,  $K_2(2)$ ,  $K_2(3)$ ,  $K_2(4)$ ,  $K_2(5)$ ,  $K_2(6)$ ,  $K_2(7)$ ,  $K_2(8)$ ,  $K_2(9)$

$$\bar{k}_2 = \frac{\sum_{i=0}^9 k_2(i)}{10}$$

$$\sigma_{k_2} = \sqrt{\frac{\sum_{i=0}^9 (k_2(i) - \bar{k}_2)^2}{10 - 1}}$$

### 4.6.3 Asymmetry

Asymmetry of the Accelerometer shall be smaller than 50ppm. The calculation of asymmetry shall be as follows:

$$\Delta K_1 = \frac{K_1(+)-K_1(-)}{K_1} \quad (16)$$

$\Delta K_1$ : Asymmetry

$K_1(-)$ : Scale factor coefficient for positive accelerations

$K_1(-)$ : Scale factor coefficient for negative accelerations

#### 4.7 Bandwidth

Bandwidth of the Accelerometer shall be greater than 60Hz. The measurement shall be done on a digitally controlled vibrational platform. The bandwidth is defined as the frequency corresponding to a phase shift of 90°.

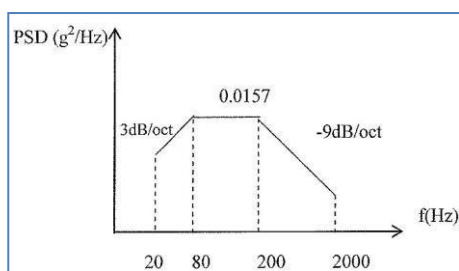

#### 4.8 Angular random walk

Angular random walk of the Accelerometer shall be smaller than  $50\mu\text{g}/\sqrt{\text{Hz}}$ . Angular random walk shall be determined from the value of Allan Variance curve where the slope is 1.

#### 4.9 Acceleration range

**The measurement range** of the Accelerometer shall be bigger than  $\pm 50\text{g}$ . The measurement shall be done on a centrifugal platform. The Accelerometer shall make meaningful maximum acceleration measurements of at least 50g.

**Vibration:** The Accelerometer shall be resistant to vibrations of 15g amplitude between 20-2000Hz. The measurement shall be done on a digitally controlled vibration platform. The Accelerometer shall make meaningful acceleration measurements under vibrations of 5g amplitude sweeping from 20Hz to 2000Hz.

**Shock:** The Accelerometer shall be resistant to half-sine wave shocks of 100g amplitude of 11 ms duration. The measurement shall be done on a digitally controlled mechanical shock platform. The Accelerometer shall make meaningful acceleration measurements under half-sine wave mechanical shocks of 100g amplitude of 11 ms duration.

**Operating temperature:** The Accelerometer shall be able to operate between -55°C and 125°C. The measurement shall be done in an environmental control chamber. The Accelerometer shall make meaningful acceleration measurements between -55°C and 125°C.

**Resolution:** The resolution of the electronic reading device for Accelerometer measurements shall be smaller than 5µg.

**Weight:** The Accelerometer shall be lighter than 80gr.

#### 4.9 EMI/EMC requirements

Seller shall provide information about their quality standards, the design procedures used for EMI/EMC compliance, standards used for EMI/EMC compliance together with exceptional frequencies and their levels if any.

#### 4.10 Calibration requirements

Seller shall define and propose the related equipment, tools and their specifications together with the related training for the user level calibration of the Accelerometer in the Proposal.

Periodical performance checks and self-tests of the Accelerometer shall be defined by Seller in the Proposal.

### 5. Quality assurance provision

The product provided shall meet the salient characteristics of this specification; conform to the Seller's drawings, specifications, standards and quality assurance practices. Quality conformance inspection shall be applied to the Accelerometer prior to being offered for acceptance under the contract. Failure of the Accelerometer to pass the examination, test or inspection shall be cause for rejection. The buyer reserves the right to require proof of such conformance.

No less than two operational tests shall be performed by operating the Accelerometer with pre-described processes decided by the Buyer. After these tests the Accelerometer shall be accepted.